

Control valve RV

Control valve with solenoid valve RVS

TECHNICAL INFORMATION

- Large control ratio of 100:1
- High control accuracy
- Three-point step or continuous control
- Easy to switch between Automatic and Manual mode
- Position feedback
- Position indicator that can be read externally

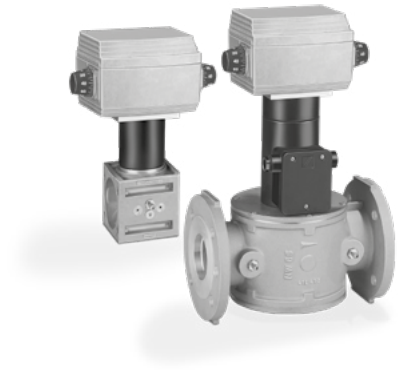

Contents

Contents	2	6.7 Setting the opening position to correspond to the input signal	20
1 Application	3	6.8 Setting the hysteresis for the input signal	20
1.1 Application examples	3	6.9 Automatic/Manual mode	20
2 Certification	5	7 Accessories	21
3 Function	6	7.1 Connection flanges for RV..ML, RVS..ML	21
3.1 Connection diagram for RV..S1, RVS..S1 actuator	8	7.2 Installation sets RP RV, RS RV	21
3.1.1 Three-point step control	8	7.3 Installation set RP RV, feedback potentiometer	21
3.1.2 Position feedback	9	7.4 Installation set RS RV, feedback current sensor	21
3.1.3 Leakage currents in parallel circuits	9	7.5 Seal set	22
3.2 Connection diagram for RV..E, RVS..E actuator	10	8 Technical data	23
3.2.1 Continuous control	10	8.1 Ambient conditions	23
3.2.2 Position feedback	10	8.2 Mechanical data	23
3.3 Connection diagram for solenoid valve RVS with cable gland	11	8.3 Electrical data	24
3.4 Connection diagram for solenoid valve RVS with plug	11	9 Dimensions	25
4 Flow rate	12	9.1 RV..ML	25
4.4.1 Calculating the nominal size	12	9.2 RV..F	26
4.1 RV	13	9.3 RVS..ML	27
4.2 RVS	14	9.4 RVS..F	28
5 Selection	15	10 Converting units	29
5.1 RV selection table	15	11 Maintenance cycles	30
5.2 RVS selection table	16	For more information	31
5.3 ProFi	17		
5.4 Type code	17		
6 Project planning information	18		
6.1 Installation	18		
6.1.1 Installation position	18		
6.2 Test points	18		
6.3 Control characteristic, valve authority	19		
6.4 Cable selection	19		
6.5 Use of interference suppression capacitors	19		
6.6 Selecting the input signal	19		

1 Application

The control valve RV is designed for regulating flow rates for modulating-controlled combustion processes on gas and air appliances which require a large control ratio of up to 100:1. It is suitable for use in electronic or mechanical gas/air ratio control systems.

The valve ensures exact adjustment of the burner capacity.

It is actuated by a three-point step controller or, in the case of the RV..E/RVS..E, by a continuous signal (e.g. 4 to 20 mA). The RV..E/RVS..E features electronic positioning control which ensures high control accuracy.

The ratio between the input signal and the flow rate is largely linear over the entire control range.

The minimum and maximum flow rates are adjusted using two infinitely adjustable switching cams. Intermediate positions can be checked or external devices can be activated via two floating auxiliary switches.



RV..ML



RVS..F

RVS

The RVS also features an integrated safety shut-off valve so that the gas can be safeguarded and controlled without any additional pressure loss.

Automatic/Manual mode

Switchover between Automatic and Manual mode facilitates setting of the infinitely adjustable switching cams during commissioning. This enables precise settings even in the low-fire rate range.

The switching point is set directly on the cams.

1.1 Application examples

The devices are used in mixing systems in the glass industry, in thermal incineration plants, in applications in the ceramics industry or for oxygen control on gas engines in combined heating and power plants.

Application



Mixing system in the glass industry



Mixing system in the glass industry

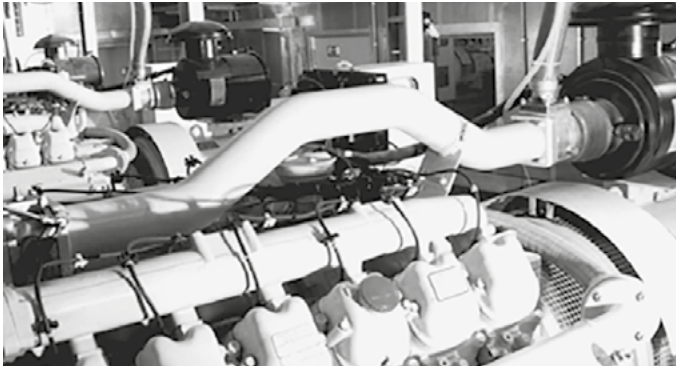

Gas engine in a combined heating and power plant

2 Certification

Certificates – see www.docuthek.com

EU certified



- 2014/35/EU (LVD), Low Voltage Directive
- 2014/30/EU (EMC), Electromagnetic Compatibility Directive
- 2011/65/EU, RoHS II
- 2015/863/EU, RoHS III
- (EU) 2016/426 (GAR), Gas Appliances Regulation
- EN 161:2011+A3:2013
- EN 126:2012

Eurasian Customs Union



The products RV, RVS meet the technical specifications of the Eurasian Customs Union.

3 Function

If the actuator is energized electrically, the gear moves the cam disk. This opens the control valve via the lever mechanism. The cam disk moves until the set position of the switching cams is reached. When the voltage is disconnected, the control valve remains in its current opening position.

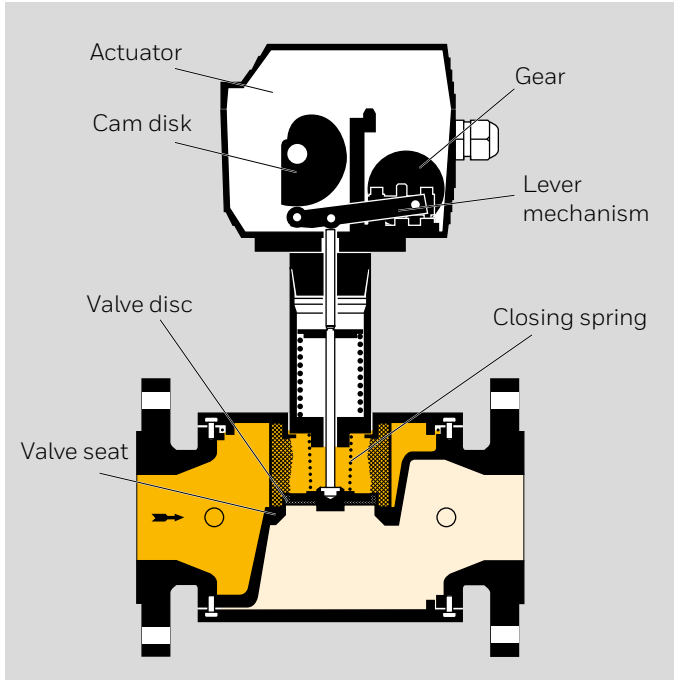

RV..F

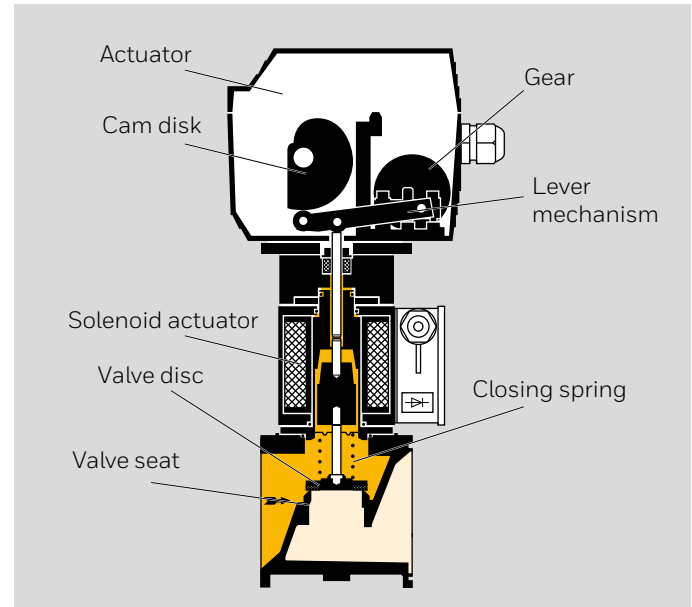

RVS..ML

RVS

The RVS also assumes the functions of a safety shut-off valve. It is closed when de-energized. The closing spring presses the valve plate on to the valve seat, thus shutting off the gas supply safely.

RV..E, RVS..E

Continuous control is effected via a setpoint device (0 (4)–20 mA, 0–10 V).

Feedback

A feedback potentiometer and an optional current sensor offer the possibility of monitoring and signalling back the current opening for the RV..S1, RVS..S1.

The RV..E, RVS..E features this function via the continuous output signal 4–20 mA as standard.

3.1 Connection diagram for RV..S1, RVS..S1 actuator

The connection diagram refers to the closed control valve.

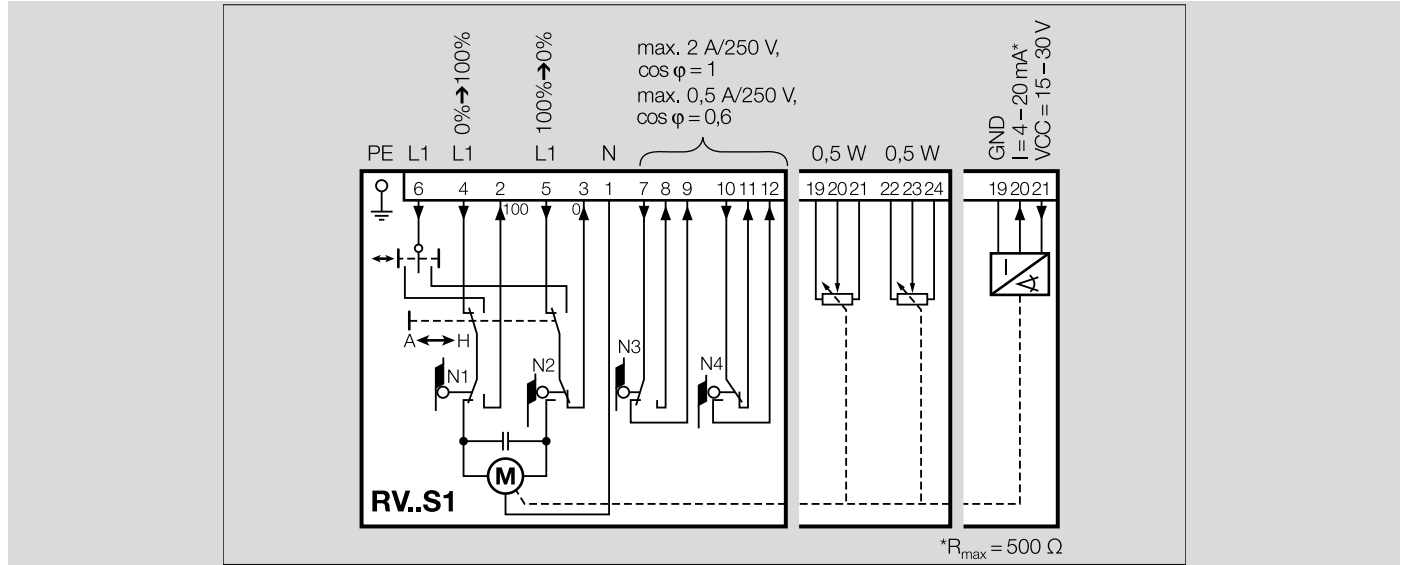

3.1.1 Three-point step control

In the case of default setting "Closed":

The control element opens when voltage is applied to terminal 4 (0 → 100%).

The control element closes when voltage is applied to terminal 5 (100 → 0%).

When the voltage is disconnected, the control valve remains in its current position.

Terminals 7 to 12 are intended for floating auxiliary switches.

3.1.2 Position feedback

As an option, potentiometers or a current sensor can be connected to terminals 19 to 24 for feedback. This allows the current position of the actuator to be monitored, see accessories for feedback: page 21 (Installation set RP RV, feedback potentiometer) or page 21 (Installation set RS RV, feedback current sensor).

The available feedback range of the feedback potentiometer depends on the adjustment of switching cams N1 and N2.

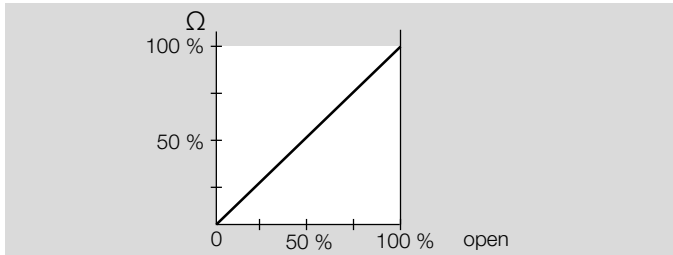

3.1.3 Leakage currents in parallel circuits

When operating two or more actuators in parallel, the three-point step controller (terminals 4 and 5) must be electrically isolated to avoid leakage currents. We recommend using relays.

3.2 Connection diagram for RV..E, RVS..E actuator

The connection diagram refers to the closed control valve.

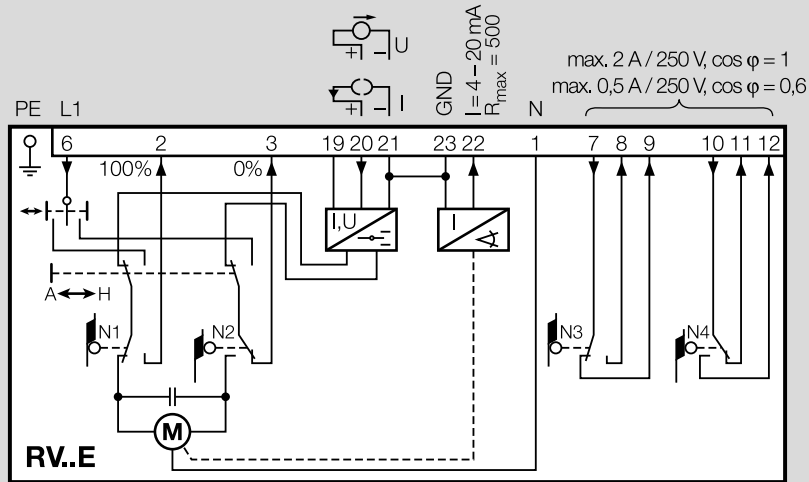

3.2.1 Continuous control

Voltage is applied to terminal 6. The actuator reacts to the setpoint specification 0–10 V or 0 (4)–20 mA via terminals 20 and 21.

The continuous signal corresponds to the opening position to be approached (e.g. with a 0 to 20 mA signal, 10 mA correspond to 50% opening).

Terminals 7 to 12 are intended for floating auxiliary switches.

3.2.2 Position feedback

The current position of the actuator can be monitored via the continuous 4–20 mA output signal at terminals 22 and 23.

3.3 Connection diagram for solenoid valve RVS with cable gland

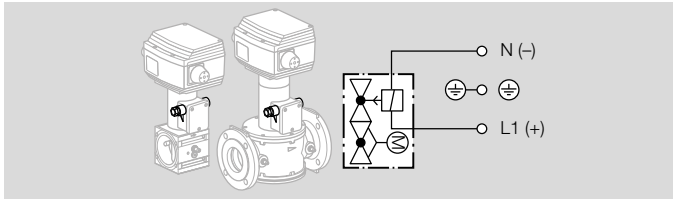

3.4 Connection diagram for solenoid valve RVS with plug

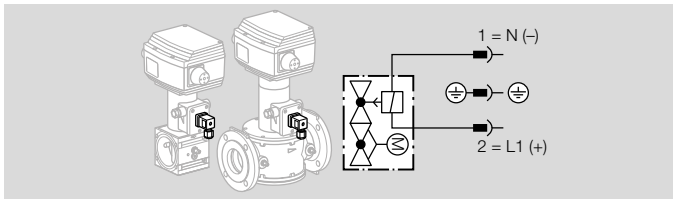

4 Flow rate

4.4.1 Calculating the nominal size

A web app for calculating the nominal size is available at www.adlatus.org.

4.1 RV

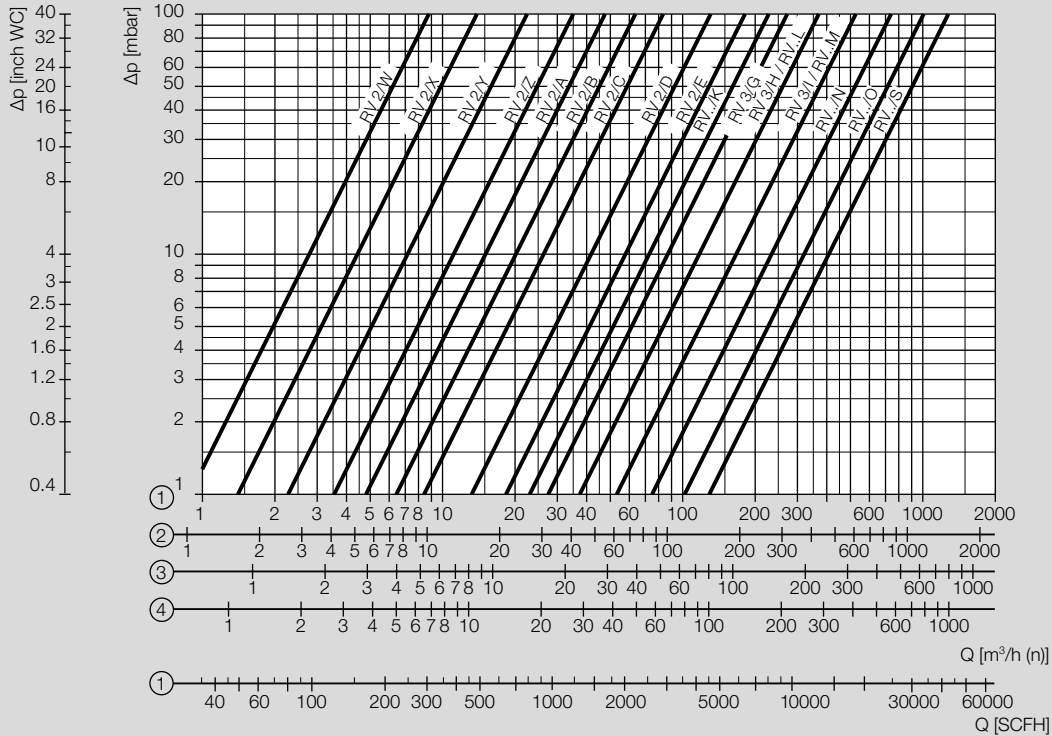

- 1 = natural gas ($\rho = 0.80 \text{ kg/m}^3$)
- 2 = town gas ($\rho = 0.64 \text{ kg/m}^3$)
- 3 = propane ($\rho = 2.01 \text{ kg/m}^3$)
- 4 = air ($\rho = 1.29 \text{ kg/m}^3$)

RV 2ML, RV 3ML: the flow rates were determined with fitted flanges. Flanges with the largest nominal diameter possible for the respective valve seat were selected.

4.2 RVS

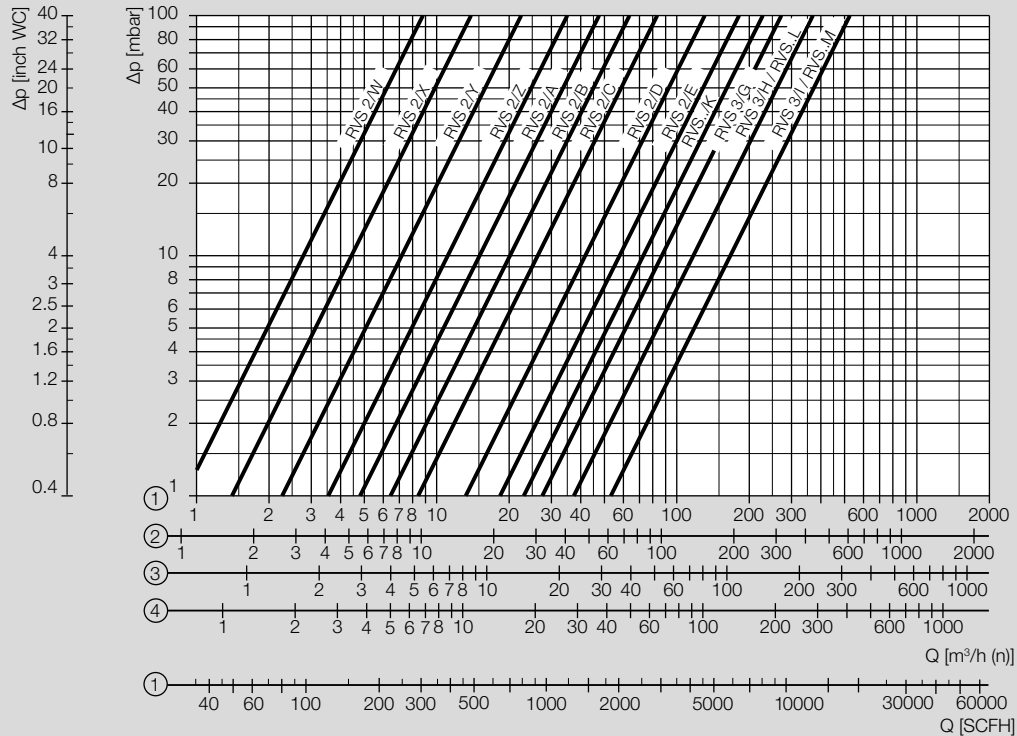

- 1 = natural gas ($\rho = 0.80 \text{ kg/m}^3$)
- 2 = town gas ($\rho = 0.64 \text{ kg/m}^3$)
- 3 = propane ($\rho = 2.01 \text{ kg/m}^3$)
- 4 = air ($\rho = 1.29 \text{ kg/m}^3$)

RVS 2ML, RVS 3ML: the flow rates were determined with fitted flanges. Flanges with the largest nominal diameter possible for the respective valve seat were selected.

5 Selection

5.1 RV selection table

Valve seat selection, see flow rate, page 13 (RV).

MODULINE connection flange with Rp internal thread to ISO 7-1

Option	RV..03 p _u max. 360 mbar	RV..05 p _u max. 500 mbar	RV..10 p _u max. 1000 mbar
Size	3	2, 3	2, 3
Valve seat	/I	/E, /H	/A, /B, /C, /D, /G, /W, /X, /Y, /Z
Pipe connection	ML	ML	ML
Mains voltage	Q, W	Q, W	Q, W
Running time	30, 60	30, 60	30, 60
Control	S1, E	S1, E	S1, E
Viton valve plate seal*	V	V	V

* Available as an option

Connection flange to ISO 7005, PN 16

Option	RV..01 p _u max. 150 mbar	RV..02 p _u max. 200 mbar	RV..03 p _u max. 360 mbar	RV..05 p _u max. 500 mbar	RV..10 p _u max. 1000 mbar
DN	100	65, 80, 100	50, 65, 80	40, 50, 65	40, 50
Valve seat	/S	/N, O	/M	/L	/K
Pipe connection	F	F	F	F	F
Mains voltage	Q, W	Q, W	Q, W	Q, W	Q, W
Running time	30, 60	30, 60	30, 60	30, 60	30, 60
Control	S1, E	S1, E	S1, E	S1, E	S1, E
Viton valve plate seal*	V	V	V	V	V

* Available as an option

5.2 RVS selection table

Valve seat selection, see flow rate, page 14 (RVS).

MODULINE connection flange with Rp internal thread to ISO 7-1

Option	RVS..02	RVS..03	RVS..05	RVS..10
	p _u max. 200 mbar	p _u max. 360 mbar	p _u max. 500 mbar	p _u max. 1000 mbar
Size	2, 3	2, 3	2, 3	2
Valve seat	/E, /I	/D, /H	/C, /G	/A, /B, /W, /X, /Y, /Z
Pipe connection	ML	ML	ML	ML
Mains voltage	Q, W	Q, W	Q, W	Q, W
Running time	30, 60	30, 60	30, 60	30, 60
Control	S1, E	S1, E	S1, E	S1, E
Electrical connection	-3, -6	-3, -6	-3, -6	-3, -6
Viton valve plate seal*	V	V	V	V

* Available as an option

Order example

RVS 2/AML10W60E-3

Connection flange to ISO 7005, PN 16

Option	RVS..02	RVS..03	RVS..05
	p _u max. 200 mbar	p _u max. 360 mbar	p _u max. 500 mbar
DN	50, 65	40, 50, 65	40, 50
Valve seat	M	L	K
Pipe connection	F	F	F
Mains voltage	Q, W	Q, W	Q, W
Running time	30, 60	30, 60	30, 60
Control	S1, E	S1, E	S1, E
Electrical connection	-3, -6	-3, -6	-3, -6
Viton valve plate seal*	V	V	V

* Available as an option

5.3 ProFi

A web app selecting the correct product is available at www.adlatus.org.

5.4 Type code

RVS	Control valve with solenoid valve
RV	Control valve
2	Size 2
3	Size 3
40-100	DN 40-100
/A-/Z	Valve seats A-Z
ML	MODULINE system
F	Flange to ISO 7005
01	p_u max. 150 mbar
02	p_u max. 200 mbar
03	p_u max. 360 mbar
05	p_u max. 500 mbar
10	p_u max. 1000 mbar
W	Mains voltage 230 V AC, 50/60 Hz
Q	Mains voltage 120 V AC, 50/60 Hz
30	30 s running time
60	60 s running time
S1	Three-point step control
E	Continuous control
-3	Solenoid valve terminal connection box
-6	Solenoid valve connection box with standard plug
V	Viton valve disc seal

* Available as an option

6 Project planning information

6.1 Installation

Sealing material and thread cuttings must not be allowed to get into the housing. We recommend installing an inlet flange with integrated strainer. A strainer is integrated in the RV..F, RVS..F.

Connection flanges for RV..ML, RVS..ML must be ordered separately and can be fitted or delivered enclosed as an additional item, see page 21 (Connection flanges for RV..ML, RVS..ML).

The pipe system must be designed in such a way so as to avoid strain at the connections.

Do not store or install the unit in the open air.

6.1.1 Installation position

RV installation position: as required.

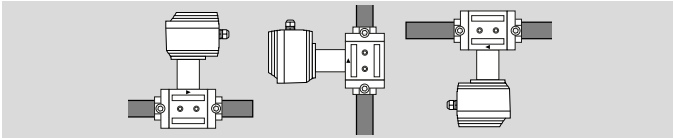

RVS installation position: not upside down.

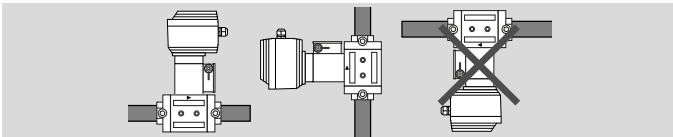

The housing must not be in contact with masonry. Minimum clearance 20 mm (0.78").

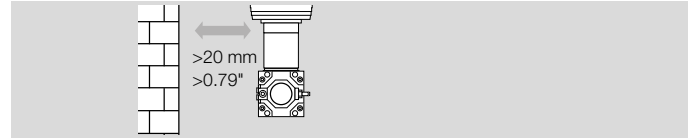

6.2 Test points

The inlet pressure p_u and the outlet pressure p_d can be measured using the pressure test points on both sides. There are two pressure test points on the RV..F and RVS..F, while the RV..ML and RVS..ML have one pressure test point at the inlet.

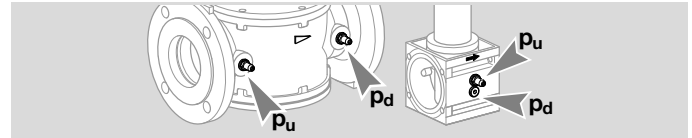

Measuring connections, see page 23 (Mechanical data).

6.3 Control characteristic, valve authority

The control behaviour is largely linear over the entire control range.

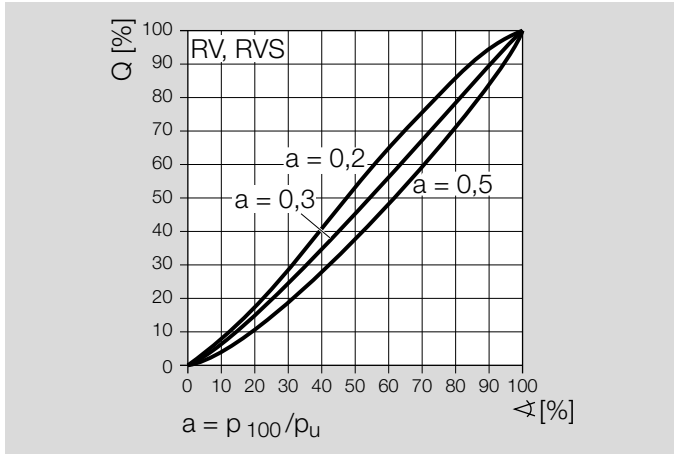

In order for the control element to be able to influence the flow rate, a proportion of the pressure loss Δp from the entire system has to be caused by the control element. Taking into consideration that the overall pressure loss Δp should be kept to a minimum, a valve authority $a = 0.3$ is recommended for the control element. This means that of the overall pressure loss Δp , there is a 30% drop on the fully open control element.

6.4 Cable selection

Use temperature-resistant cable ($> 90^\circ\text{C}$). Install supply and signal lines separately. Cables should be installed well away from high-voltage lines of other devices.

Observe EMC Directive for installation of signal lines.

Use cables with wire end ferrules. Cable cross-section: max. 2.5 mm².

Conductors which have not been connected (spare conductors) must be insulated at their ends.

6.5 Use of interference suppression capacitors

Interference suppression capacitors installed in the system must only be used in conjunction with a series resistor so as not to exceed the maximum current – see page 23 (Technical data).

6.6 Selecting the input signal

RV..E, RVS..E

The input signal type is selected using DIP switches.

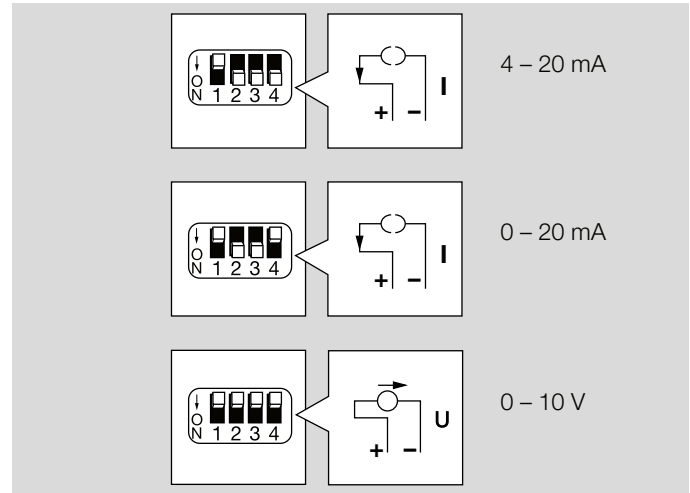

6.7 Setting the opening position to correspond to the input signal

RV..E, RVS..E

The minimum and maximum opening positions can be set using potentiometers P1 and P2.

P1 = closed position (approx. 0–50%)

P2 = open position (approx. 50–100%)

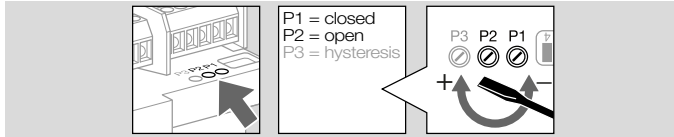

6.8 Setting the hysteresis for the input signal

RV..E, RVS..E

The positioning control hysteresis can be adjusted on a potentiometer. This suppresses fluctuations or interference in the input signal.

The hysteresis can be reduced and the control accuracy increased by turning the potentiometer screw clockwise.

After changing the setting, ensure that the actuator does not oscillate when operating.

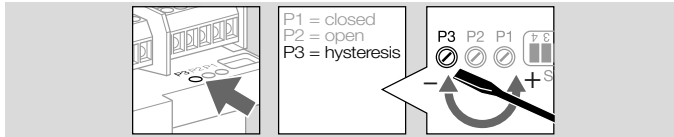

6.9 Automatic/Manual mode

For commissioning, it is possible to switch between Automatic and Manual mode using a slide switch.

Manual mode facilitates setting. The actuator can be opened and closed manually using the toggle switch.

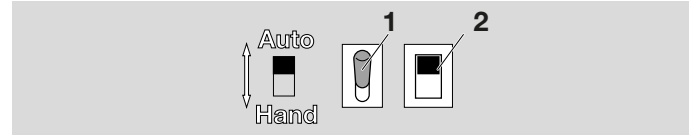

1 Slide switch

2 Toggle switch

7 Accessories

7.1 Connection flanges for RV..ML, RVS..ML

Connection flanges for RV..ML, RVS..ML must be ordered separately and can be fitted (..E) or delivered enclosed as an additional item (..B). The inlet flange is available with integrated strainer.

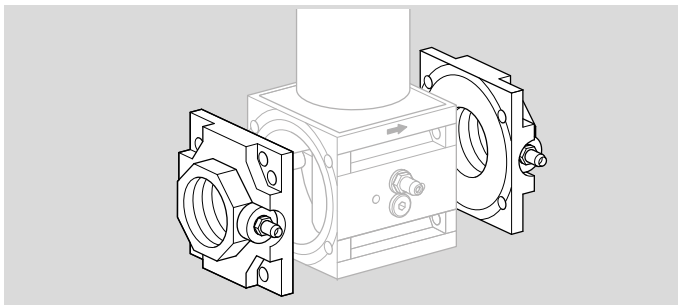

Connection flanges:

Size 2: nominal diameters DN 25 and DN 40

Size 3: nominal diameters DN 40 and DN 50

7.2 Installation sets RP RV, RS RV

Older and current versions of installation sets RP RV and RS RV can be used in older and current gearboxes.

7.3 Installation set RP RV, feedback potentiometer

Can only be retrofitted on RV..S1, RVS..S1.

The power consumption of the potentiometer is max. 0.5 W.

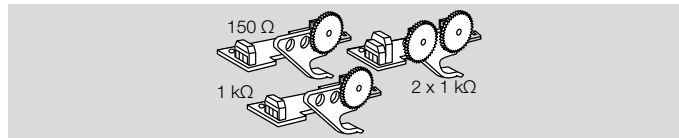

Installation set for resistance value:

150 Ω: Order No. 74926119,

1 kΩ: Order No. 74926121,

2 x 1 kΩ: Order No. 74926123.

7.4 Installation set RS RV, feedback current sensor

Can only be retrofitted on RV..S1, RVS..S1.

4 to 20 mA for feedback on the current position of the control valve.

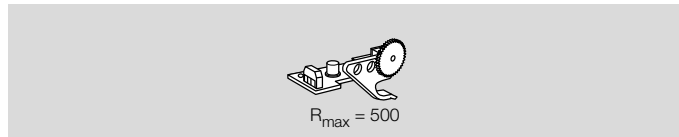

Order No. 74926117

7.5 Seal set

We recommend replacing the seals during maintenance work.

RV..ML, RVS..ML

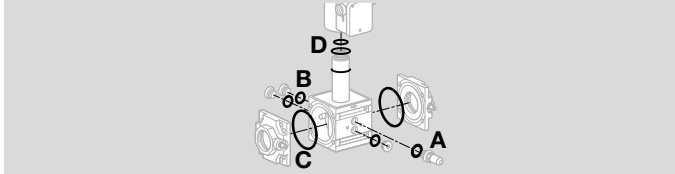

RV 2..ML, RVS 2..ML: Order No. 74926010

RV 3..ML, RVS 3..ML: Order No. 74926011

Scope of delivery:

A 1 c

B 3 x sealing rings for screw plugs

C 2 x O-rings for inlet and outlet flanges

D 3 x O-rings for guide tube (RVS only)

RV..F, RVS..F

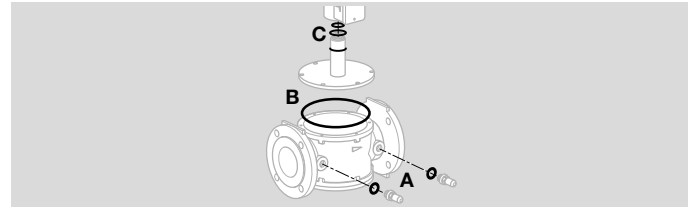

RV 40, RVS 40: Order No. 74926012

RV 50, RVS 50: Order No. 74926013

RV 65, RVS 65: Order No. 74926014

RV 80, RV 100: Order No. 74926015

Scope of delivery:

A 2 x flat seals for pressure test points

B 1 x O-ring for housing cover

C 3 x O-rings for guide tube (RVS 40–65)

8 Technical data

8.1 Ambient conditions

Icing, condensation and dew in and on the unit are not permitted.

Avoid direct sunlight or radiation from red-hot surfaces on the unit. Note the maximum medium and ambient temperatures!

Avoid corrosive influences, e.g. salty ambient air or SO₂.

The unit may only be stored/installed in enclosed rooms/buildings.

The unit is suitable for a maximum installation height of 2000 m AMSL.

Ambient temperature: -20 to +60°C
(-4 to +140°F).

With optional Viton valve plate seal:
0 to +60°C (32 to 140°F).

Long-term use in the upper ambient temperature range accelerates the ageing of the elastomer materials and reduces the service life (please contact manufacturer).

Transport temperature = ambient temperature.

Storage temperature: -20 to +40°C (-4 to +104°F).

Enclosure: IP 54 pursuant to IEC 529.

This unit is not suitable for cleaning with a high-pressure cleaner and/or cleaning products.

8.2 Mechanical data

Suitable gas types: natural gas, town gas, LPG (gaseous), biogas (max. 0.1 %-by-vol. H₂S) and air.

The gas must be clean and dry in all temperature conditions and must not contain condensate.

Medium temperature = ambient temperature.

Max. inlet pressure $p_{u,max.}$: 150 to 1000 mbar.

Measuring connections:

RV..ML, RVS..ML: Rp 1/8 on both sides,

RV..F, RVS..F: Rp 1/4 on both sides.

Connection flanges:

RV..ML, RVS..ML: Rp internal thread to ISO 7-1,

RV..F, RVS..F: flange to ISO 7005, PN 16.

Max. tightening torque: 3 Nm on projecting shaft.

Housing: AISi.

Valve plate seal: Perbunan.

RVS, solenoid actuator:

Solenoid valve (on RVS) with spring-loaded valve plate, closed when de-energized, Class A, Group 1 to EN 161.

Closing time: < 1 s.

8.3 Electrical data

Mains voltage:

230 V AC, -15/+10%, 50/60 Hz,

120 V AC, -15/+10%, 50/60 Hz.

Safety class: I.

RVS, solenoid actuator:

Cable cross-section: max. 2.5 mm².

Cable gland:

PG 13.5 – apart from RVS 232ML = PG 11, plug with socket to EN 175301-803.

Duty cycle: 100%.

Electrical connection:

According to the data table, the electrical power is identical when switching on and in continuous operation. Power factor of the solenoid coil: $\cos \varphi = 1$.

RV, RVS, actuator:

Cable cross-section: max. 1.5 mm².

Cable gland:

RV, RVS: 2 x M20,

RV..E, RVS..E: 3 x M20.

RV..E with integrated positioning control. The following signal types are processed:

0 (4) to 20 mA,

0 to 10 V.

Input resistance:

0 (4) to 20 mA: 50 Ω (load impedance),

0 to 10 V: 150 kΩ (input resistance).

Running time for 0 to 100% at 50 Hz: 30 s and 60 s.

Running times are reduced by a factor of 0.83 at 60 Hz compared to 50 Hz:

	Running time [s/90°]	
	50 Hz	60 Hz
RV..30, RVS..30	30	25
RV..60, RVS..60	60	50

Contact rating of the cam switches:

Voltage	Min. current (resistive load)	Max. current (resistive load)
24–230 V, 50/60 Hz	1 mA	2 A
24 V DC	1 mA	100 mA

Typical designed lifetime of the cam switches:

Switching current	Switching cycles	
	$\cos \varphi = 1$	$\cos \varphi = 0.3$
1 mA	1,000,000	–
22 mA ¹⁾	–	1,000,000
100 mA	1,000,000	–
2 A	100,000	–

1) Typical contactor application (230 V, 50/60 Hz, 22 mA, $\cos \varphi = 0.3$)

9 Dimensions

9.1 RV..ML

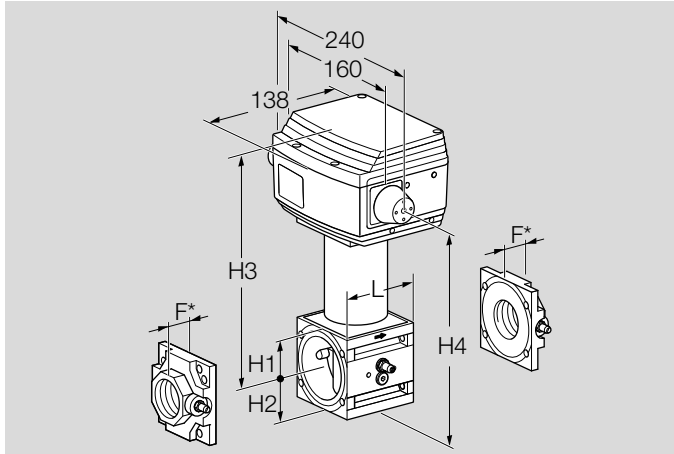

Type	Seat [mm]	Connection	$p_{u \text{ max.}}$ [mbar]	Dimensions [mm]						k [m ³ /h]	Power [VA/W]		Weight [kg]
				L	H1	H2	H3	H4	F*		120 V AC	230 V AC	
RV 2/W	5	Rp 1, Rp 11/2	1000	96	48	49	253	235	34	0.8	4.8	4.8	4.2
RV 2/X	6	Rp 1, Rp 11/2	1000	96	48	49	253	235	34	1.3	4.8	4.8	4.2
RV 2/Y	7.5	Rp 1, Rp 11/2	1000	96	48	49	253	235	34	2	4.8	4.8	4.2
RV 2/Z	9.5	Rp 1, Rp 11/2	1000	96	48	49	253	235	34	3.2	4.8	4.8	4.2
RV 2/A	11.5	Rp 1, Rp 11/2	1000	96	48	49	253	235	34	4.3	4.8	4.8	4.2
RV 2/B	13.8	Rp 1, Rp 11/2	1000	96	48	49	253	235	34	5.8	4.8	4.8	4.2
RV 2/C	16.5	Rp 1, Rp 11/2	1000	96	48	49	253	235	34	7.7	4.8	4.8	4.2
RV 2/D	23	Rp 1, Rp 11/2	1000	96	48	49	253	235	34	12	4.8	4.8	4.2
RV 2/E	32	Rp 1, Rp 11/2	500	96	48	49	253	235	34	17	4.8	4.8	4.2
RV 3/G	32	Rp 11/2, Rp 2	1000	130	63	72	284	291	42	26	4.8	4.8	5.3
RV 3/H	40	Rp 11/2, Rp 2	500	130	63	72	284	291	42	34	4.8	4.8	5.3
RV 3/I	52	Rp 11/2, Rp 2	360	130	63	72	284	291	42	46	4.8	4.8	5.3

* Order inlet and outlet flanges separately

9.2 RV..F

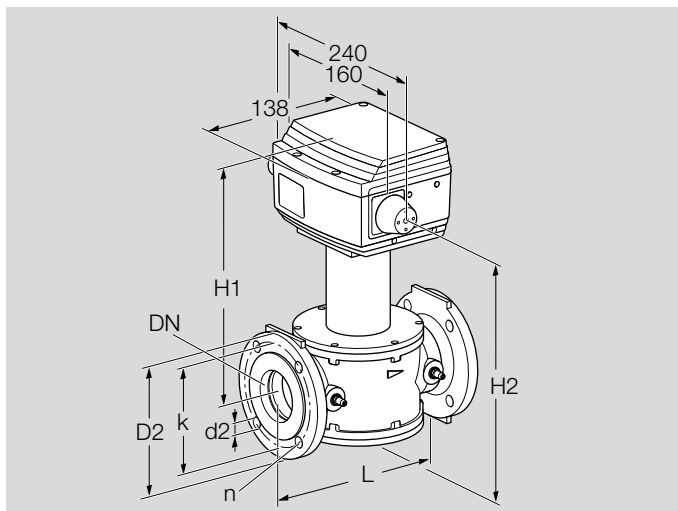

Type	Seat [mm]	Connection	p _U max. [mbar]	Dimensions [mm]						n	k [m ³ /h]	Power [VA/W]		Weight [kg]
				L	H1	H2	D2	k	120 V AC			230 V AC		
RV 40/K	31	40	1000	200	269	255	150	110	4	21	4.8	4.8	6.2	
RV 40/L	42	40	500	200	269	255	150	110	4	34	4.8	4.8	6.2	
RV 50/K	30	50	1000	230	280	277	165	125	4	21	4.8	4.8	7.6	
RV 50/L	38	50	500	230	280	277	165	125	4	34	4.8	4.8	7.6	
RV 50/M	52	50	360	230	280	277	165	125	4	46	4.8	4.8	7.6	
RV 65/L	38	65	500	290	291	300	185	145	4	34	4.8	4.8	9.6	
RV 65/M	47	65	360	290	291	300	185	145	4	46	4.8	4.8	9.6	
RV 65/N	66	65	200	290	291	300	185	145	4	66	4.8	4.8	9.6	
RV 80/M	46	80	360	310	303	323	200	160	8	46	4.8	4.8	11.8	
RV 80/N	60	80	200	310	303	323	200	160	8	66	4.8	4.8	11.8	
RV 80/O	81	80	200	310	303	323	200	160	8	93	4.8	4.8	11.8	
RV 100/N	58	100	200	350	322	367	200	180	8	66	4.8	4.8	15.8	
RV 100/O	77	100	200	350	322	367	220	180	8	93	4.8	4.8	15.8	
RV 100/S	90	100	150	350	322	367	220	180	8	110	4.8	4.8	15.8	

9.3 RVS..ML

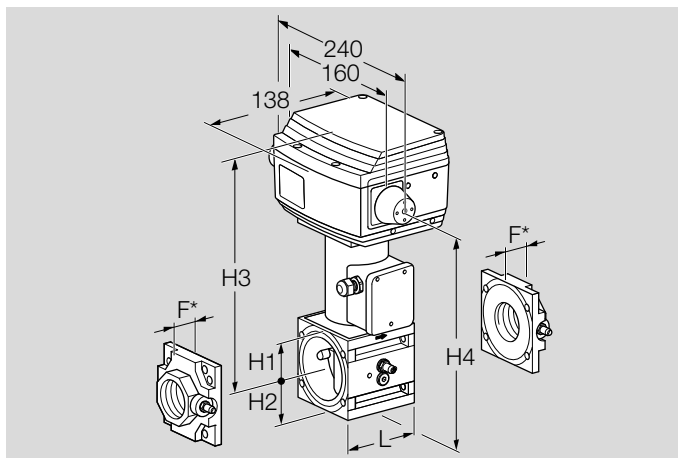

Type	Seat [mm]	Connection	p_u max. [mbar]	Dimensions [mm]						k [m ³ /h]	Power [VA/W]		Weight [kg]
				L	H1	H2	H3	H4	F*		120 V AC	230 V AC	
RVS 2/W	5	Rp 1, Rp 11/2	1000	96	48	49	277	259	34	0.8	41	47	5.3
RVS 2/X	6	Rp 1, Rp 11/2	1000	96	48	49	277	259	34	1.3	41	47	5.3
RVS 2/Y	7.5	Rp 1, Rp 11/2	1000	96	48	49	277	259	34	2	41	47	5.3
RVS 2/Z	9.5	Rp 1, Rp 11/2	1000	96	48	49	277	259	34	3.2	41	47	5.3
RVS 2/A	11.5	Rp 1, Rp 11/2	1000	96	48	49	277	259	34	4.3	41	47	5.3
RVS 2/B	13.8	Rp 1, Rp 11/2	1000	96	48	49	277	259	34	5.8	41	47	5.3
RVS 2/C	16.5	Rp 1, Rp 11/2	500	96	48	49	277	259	34	7.7	41	47	5.3
RVS 2/D	23	Rp 1, Rp 11/2	360	96	48	49	277	259	34	12	41	47	5.3
RVS 2/E	32	Rp 1, Rp 11/2	200	96	48	49	277	259	34	17	41	47	5.3
RVS 3/G	32	Rp 11/2, Rp 2	500	130	63	72	360	367	42	26	78	91	11
RVS 3/H	40	Rp 11/2, Rp 2	360	130	63	72	360	367	42	34	78	91	11
RVS 3/I	52	Rp 11/2, Rp 2	200	130	63	72	360	367	42	46	78	91	11

* Order inlet and outlet flanges separately

9.4 RVS..F

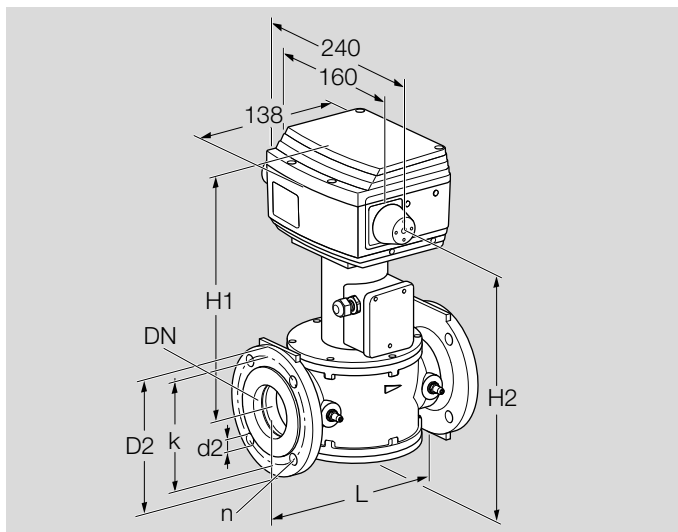

Type	Seat [mm]	Connection	$p_{u \max.}$ [mbar]	Dimensions [mm]						k [m ³ /h]	Power [VA/W]		Weight [kg]
				L	H1	H2	D2	k	n		120 V AC	230 V AC	
RVS 40/K	31	40	500	200	345	331	150	110	4	21	78	91	11.1
RVS 40/L	42	40	360	200	345	331	150	110	4	34	78	91	11.1
RVS 50/K	30	50	500	230	356	353	165	125	4	21	78	91	12.5
RVS 50/L	38	50	360	230	356	353	165	125	4	34	78	91	12.5
RVS 50/M	52	50	200	230	356	353	165	125	4	46	78	91	12.5
RVS 65/L	38	65	360	290	367	376	185	145	4	34	78	91	14.5
RVS 65/M	47	65	200	290	367	376	185	145	4	46	78	91	14.5

10 Converting units

See www.adlatus.org

11 Maintenance cycles

At least once a year, at least twice a year in the case of biogas.

If the flow rate drops, clean the strainer.

For more information

The Honeywell Thermal Solutions family of products includes Honeywell Combustion Safety, Eclipse, Exothermics, Hauck, Kromschroder and Maxon. To learn more about our products, visit ThermalSolutions.honeywell.com or contact your Honeywell Sales Engineer.

Elster GmbH
Strotheweg 1, D-49504 Lotte
T +49 541 1214-0
hts.lotte@honeywell.com
www.kromschroeder.com

© 2020 Elster GmbH

We reserve the right to make technical modifications in the interests of progress.

